

ITEM NO.	DESCRIPTION	QTY.
1	PW FOAMED TUBE, 96 IN LG	1
2	13/16" ID 4" ROUND WASHER, GALVANIZED	2
3	3/4" LOCKWASHER	2
4	13/16 POLYMER BASE INSERT 3.625 IN LG	2
5	3/4 - 10 SQ NUT	2
6	3/4" x 6" BOLT	2
7	HD FLANGED TANGENT BASE	1

PAPER SIZE	DRAWING NUMBER
<b>B</b>	<b>PW08ST004</b>

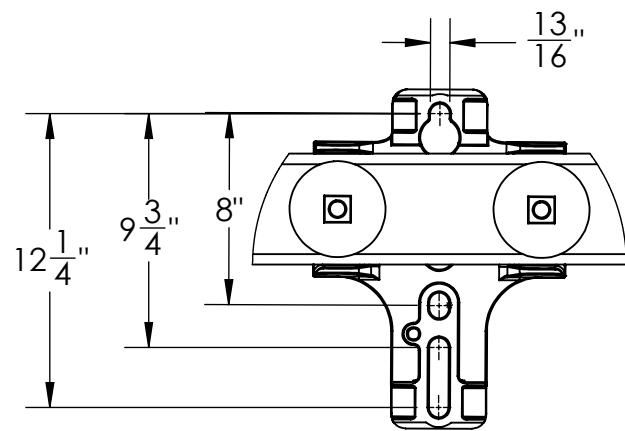

DETAIL A  
SCALE 1 : 8

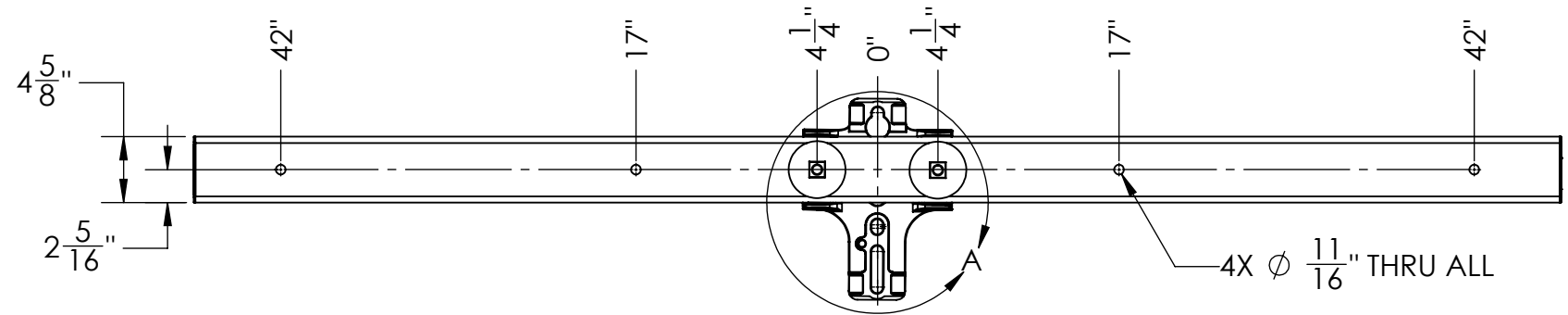
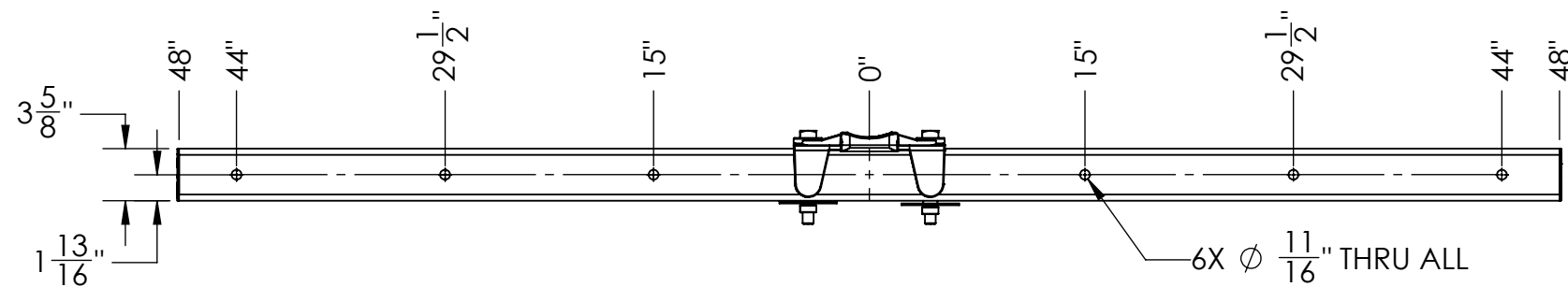
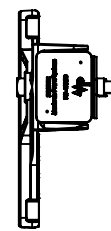

THIS DRAWING CONTAINS CONFIDENTIAL INFORMATION THAT IS THE PROPERTY OF MACLEAN POWER, L.L.C. ("MACLEAN"). USE OF MACLEAN'S CONFIDENTIAL INFORMATION WITHOUT MACLEAN'S EXPRESS WRITTEN CONSENT IS STRICTLY PROHIBITED AND MAY EXPOSE YOU TO LEGAL LIABILITY. IF YOU BELIEVE THAT YOU RECEIVED THIS MATERIAL IN ERROR, PLEASE DESTROY IT OR RETURN IT TO "MACLEAN POWER, L.L.C., 101 PARK AVE., NEWBERRY, SOUTH CAROLINA 29108, "USA."

CATALOG NUMBER: <b>PW08ST004</b>	CUSTOMER NUMBER: <b>N/A</b>	PART NUMBER: <b>F490156</b>	DRAWING NUMBER: <b>PW08ST004</b>	DO NOT SCALE DRAWING
PHYSICAL PROPERTIES			SHEET: <b>1 OF 1</b>	CAD GENERATED DRAWING DO NOT MANUALLY UPDATE
MATERIAL:	APPROX. WEIGHT : <b>41 LBS</b>	VOLUME : <b>IN3</b>	DRAWING DESCRIPTION: <b>PW TANGENT CROSSARM</b>	DESIGN DATE: <b>8/10/07</b>
UNLESS OTHERWISE SPECIFIED DIMENSIONS ARE IN: <b>INCHES</b>			PRODUCT LINE: <b>CROSSARMS</b>	DRAWN BY: <b>TJK</b>
TOLERANCES ARE: XX +/- 1/4 X/XX +/- 1/32 ANGLES +/- 1°			ENGINEER: <b>prollins</b>	APPROVED: <b>05/30/23</b>
 101 PARK AVE. NEWBERRY, SC. 29108 TEL. (803) 628-7700 FAX: (803) 628-2139			SCALE: <b>1:12.5</b>	